

# EIN RAD FÜR **ALLES**

RC ROAD NIGHT // 07.11.2023



**BERGAMONT**

WE ARE MOBILITY



An aerial photograph of a winding asphalt road that curves through a hilly, vegetated landscape. The road is dark and has white lines marking its edges. The surrounding terrain is covered in green and brown vegetation, with some rocky patches. The lighting is dramatic, with strong shadows and highlights, suggesting a low sun position.

# EIN RAD FÜR **ALLES**

BIKES FÜR ALLES

GEOMETRIE UND ERGONOMIE

ANTRIEBSKONZEPT

TUNING

ERLEBNIS STATT ERGEBNIS

IMPROVISATION & EMOTION



JAN HEINE

EIN RAD  
FÜR ALLES

DIE ALLROAD-BIKE-  
REVOLUTION



SO MACHST DU DEIN FAHRRAD SCHNELL,  
KOMFORTABEL UND ZUVERLÄSSIG

Mit einem Vorwort von Ted King

Illustrationen von MIYOSHI

covadonga

EIN RAD  
FÜR **ALLES** ???

JAN HEINE

EIN RAD  
FÜR ALLES

DIE ALLROAD-BIKE-  
REVOLUTION



SO MACHST DU DEIN FAHRRAD SCHNELL,  
KOMFORTABEL UND ZUVERLÄSSIG

Mit einem Vorwort von Ted King

Illustrationen von MIYOSHI

covadonga

EIN RAD  
FÜR **ALLES** !



JAN HEINE

## EIN RAD FÜR ALLES

DIE ALLROAD-BIKE-  
REVOLUTION



SO MACHST DU DEIN FAHRRAD SCHNELL,  
KOMFORTABEL UND ZUVERLÄSSIG

Mit einem Vorwort von Ted King  
Illustrationen von MIYOSHI

covadonga

*„Wir glauben, dass Leistungsfähigkeit wichtig ist. Das Radfahren bringt den Menschen den Vögeln nahe. Das Rad versetzt einen in die Lage, über flache Straßenabschnitte nur so hinwegzufliegen. Man gleitet bergauf, als ob man im Auftrieb einer Gewitterwolke aufsteigen würde. Man saust Abfahrten hinab wie ein Raubvogel im Sturzflug.“*

***„Je besser die Performance, die ein Rad bietet, desto mehr kann man diese Erlebnisse genießen.“***

JAN HEINE EIN RAD FÜR ALLES



# BIKES FÜR ALLES



ALLROUND / BERGAMONT GRANDURANCE ELITE



PERFORMANCE / ROSE BACKROAD



PERFORMANCE / SCOTT ADDICT GRAVEL



RACE / CANYON GRAIL



RACE / CERVÉLO ÁSPERO



LIGHTWEIGHT / PARAPERA ATMOS



# BIKES FÜR ALLES



**ALLROUND** / BERGAMONT GRANDURANCE EXPERT



**ALLROAD** / FARA F/ALL-ROAD



**GRAVITY** / YT SZEPTER



**FULL SUSPENSION** / SPECIALIZED DIVERGE STR



**FULL SUSPENSION** / CANNONDALE TOPSTONE LEFTY



**TRAVEL, ADVENTURE** / SALSA FARO



*„KOMFORT IST LEISTUNGSFÄHIGKEIT.“*

JAN HEINE EIN RAD FÜR ALLES

# GEOMETRIE UND ERGONOMIE

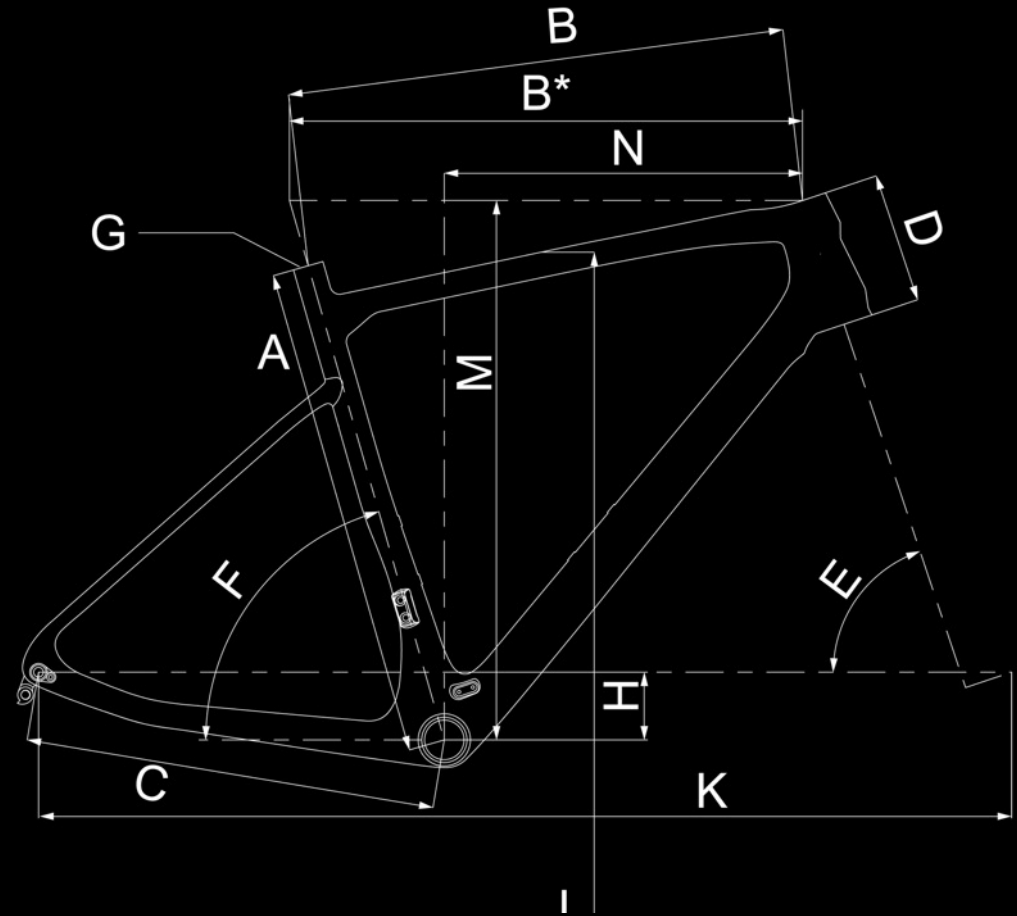

STACK (M): 598 MM

REACH (N): 390 MM



# GEOMETRIE UND ERGONOMIE

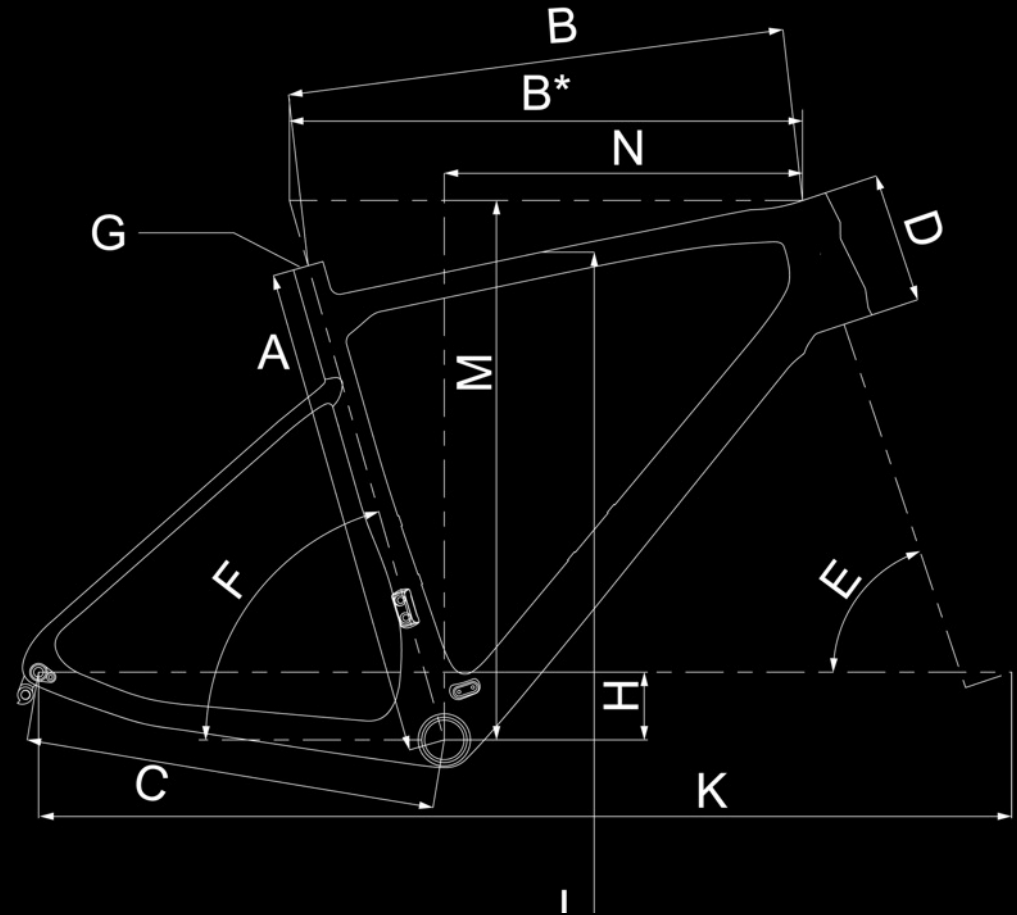

STACK TO REACH FAKTOR =  $M:N = 598:390 = 1,53$

STACK TO REACH ALLROAD > 1,35, < 1,65

# GEOMETRIE UND ERGONOMIE



SYNCROS TOFINO R 1.0 CUT-OUT

ERGON SR ALLROAD CORE



# GEOMETRIE UND ERGONOMIE



SYNCROS TOFINO R 1.0 CUT-OUT

ERGON SR ALLROAD CORE

# GEOMETRIE UND ERGONOMIE



OHNE FLARE



MIT FLARE



# GEOMETRIE UND ERGONOMIE



MTB orientiertes Pedal



ROAD BIKE orientiertes Pedal

*„MEHR LEISTUNG ODER WENIGER  
WIDERSTAND – DAS ERGEBNIS IST  
DASSELBE.“*

JAN HEINE EIN RAD FÜR ALLES



# ANTRIEBSKONZEPT



BEISPIEL SRAM, ELEKTRONISCH, FUNKGESTEUERT, WATTMESSUNG

BEISPIEL SHIMANO, MECHANISCH

# ANTRIEBSKONZEPT





*„ICH HATTE EINE GEWISSE VERBESSERUNG ERWARTET, DOCH ICH WAR ÜBERRASCHT, WIE GROSS DIESE AUSFIEL. DIE NEUEN REIFEN ROLLTEN NICHT NUR SCHNELLER. SIE HATTEN AUCH DEN CHARAKTER MEINES RADS VÖLLIG VERÄNDERT.“*

JAN HEINE EIN RAD FÜR ALLES

# TUNING



SYNCROS CAPITAL 1.0 40 MM



SYNCROS CAPITAL SL 40 MM



SYNCROS CAPITAL SL AERO 60 MM

# TUNING



SCHWALBE G-ONE ALLROUND



SCHWALBE G-ONE BITE



SCHWALBE G-ONE OVERLAND



SCHWALBE G-ONE R



SCHWALBE G-ONE RS



SCHWALBE G-ONE SPEED



SCHWALBE ONE



# TUNING

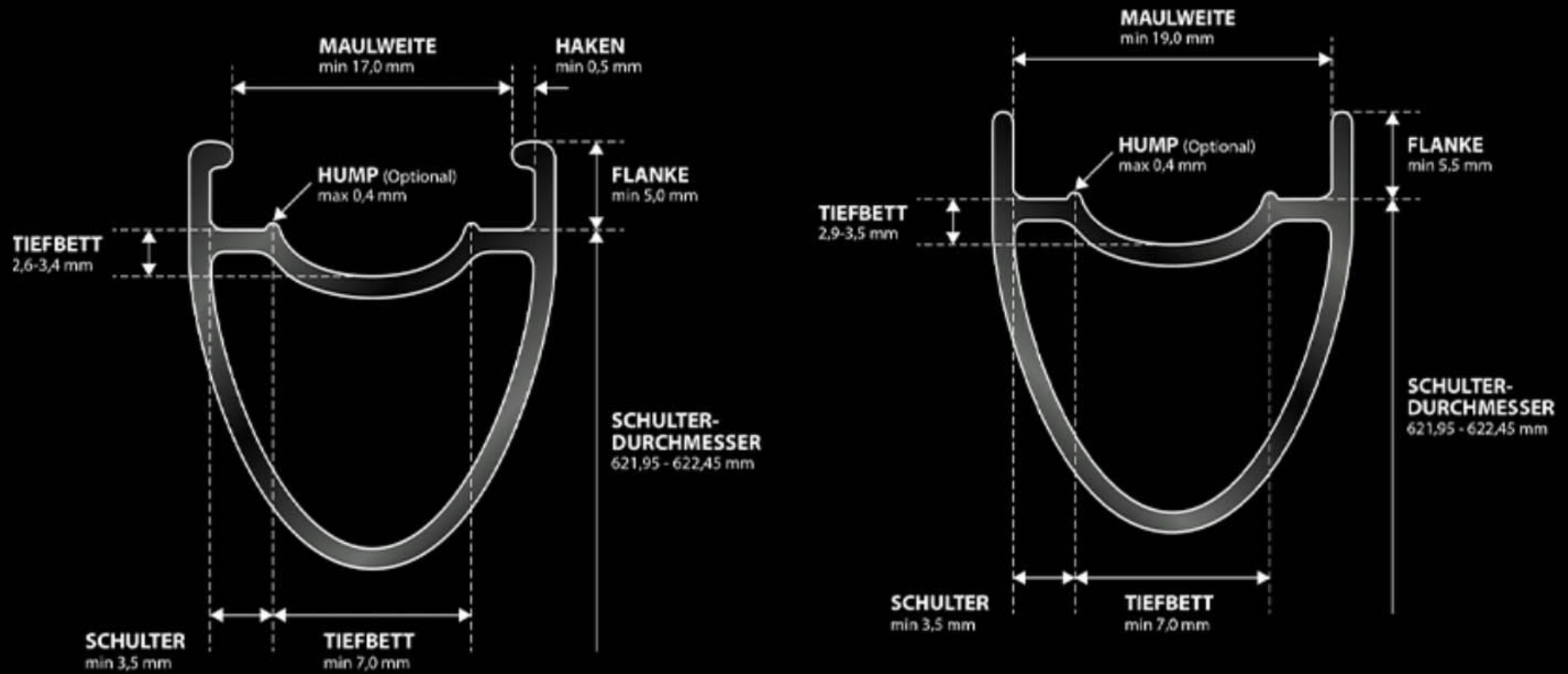

# TUNING

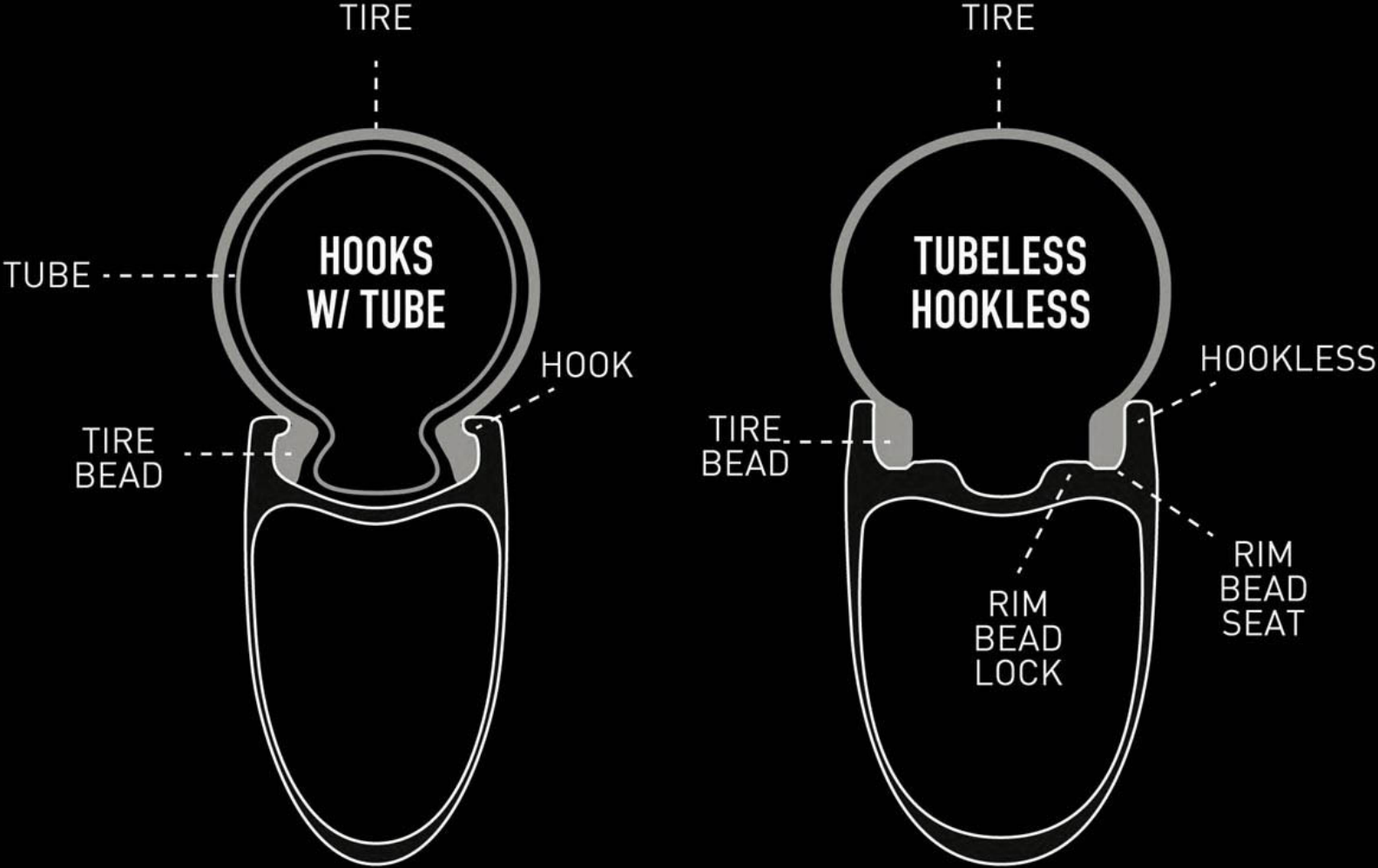

# TUNING





# TUNING



# TUNING



# TUNING



# TUNING





# TUNING



# TUNING



# TUNING

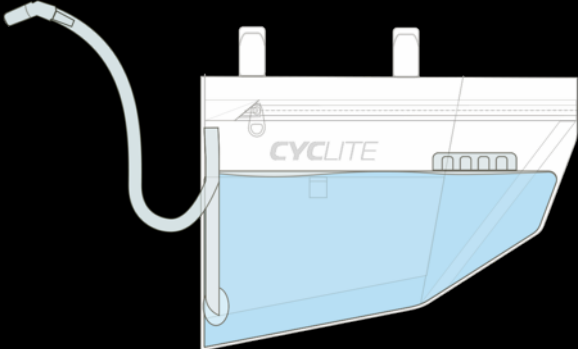

# ERLEBNIS STATT ERGEBNIS

*„WIR FUHREN WIE VÖGEL, WECHSELTEN UNSERE POSITIONEN OHNE RÜCKSICHT AUF DIE ENGEN KURVEN UND RASTEN MIT BERAUSCHENDER GESCHWINDIGKEIT DAHIN. ALS DIE STRASSE WIEDER GERADEAUS FÜHRTE UND ICH MICH AUFSETZTE, UM WIEDER LOCKERER ZU PEDALIEREN, SPÜRTE ICH EIN LEICHTES, GLÜCKLICHES GEFÜHL IN DER BRUST. ICH WAR VERLIEBT.“*

JAN HEINE EIN RAD FÜR ALLES



# ERLEBNIS STATT ERGEBNIS





# ERLEBNIS STATT ERGEBNIS





# ERLEBNIS STATT ERGEBNIS



# IMPROVISATION & EMOTION





# IMPROVISATION & EMOTION











— HORARIO —

MARTES A SÁBADO

9:00h - 17:00h

DOMINGOS y FESTIVOS

9:00 - 14:00h

DIAS CERRADOS —



























A wide-angle, high-angle photograph of a person riding a bicycle on a paved road that curves through a vast, open landscape. The scene is captured during the golden hour of sunset, with the sun low on the horizon, casting a warm, golden glow over the entire scene. The landscape is a mix of dry, brownish fields and green, grassy hills. In the distance, there are rolling hills and a small town or village. The sky is a mix of blue and orange, with a few wispy clouds. The overall mood is peaceful and serene.

*I'm taking a ride with my best friend*

*We're flying high*

*We're watching the world pass us by*

*Never want to come down*

*Never want to put my feet back down on the ground*

DEPECHE MODE NEVER LET ME DOWN AGAIN



An aerial photograph of a winding asphalt road through a valley at sunset. The sun is low on the horizon, casting a warm, golden glow over the landscape. The road curves from the left towards the right, with a cyclist riding on it. The surrounding terrain is a mix of dry grass, shrubs, and cultivated fields. In the distance, there are rolling hills and a small town or village. The sky is a mix of blue and orange, with some light clouds.

**DANKE**